



Championship Auto Racing Series
Pro Late Model Tour Rules
136 Bridlepath Lane
 Mooresville, NC 28117
Phone: (704)-662-9212
www.carsracingtour.com

UPDATED 1/6/23

RULE BOOK DISCLAIMER

The rules and/or regulations set forth herein provide for the orderly conduct of racing events and to establish minimum acceptable requirements of such events. These rules shall govern the condition of all such events. All participants are deemed to have complied with these rules. No expressed or implied warranty of safety shall result from publications of or compliance with these rules and/or regulations. Speedway rules are intended as a guide for the conduct of the sport and are in no way a guarantee against injury or death to a participant.

No expressed or implied warranty of safety shall result from publications of/or compliance with these rules and/or regulations. They are intended as a guide for the conduct of the sport and are in no way a guarantee against injury or death to a participant, spectator, or official.

By signing in at each event, all persons agree to unconditionally abide by the rules and regulations as set forth in the CARS Pro Late Model Tour Rules and Regulations---2023

CARS shall be empowered to permit reasonable and appropriate deviation from any of the specifications herein or impose any further requirements.

Any interpretation or deviation of these rules is left to the discretion of the CARS Tour Officials. Their decision is final.

Championship Auto Racing Series Management.

The rules and/or regulations set forth herein provide for the orderly conduct of racing events and to establish minimum acceptable requirements of such events. These rules shall govern the condition of all such events. All participants are deemed to have complied with these rules. No expressed or implied warranty of safety shall result from publications of or compliance with these rules and/or regulations. Speedway rules are intended as a guide for the conduct of the sport and are in no way a guarantee against injury or death to a participant.

*Series Officials shall be empowered to permit minor deviations from any of the specifications herein or impose any further restrictions that in his/her opinion does not alter the minimum acceptable requirements. No expressed or implied warranty of safety shall result from such alteration of specifications.

*Series reserves the right to update, modify, and/or delete rules at any time deemed necessary to ensure safety, fair competition or any other reason that may be appropriate.

*Unsportsmanlike-like conduct can carry a minimum **\$500.00 fine** and/or suspension.

*Any competitor that finishes in the top five (5) may be required, at their expense, to remove the intake, heads, and/or oil pan for inspection purposes.

*All cars must go through technical inspection prior to car taking to the track for practice. Cars will be weighed with driver and may be done prior to or after qualifying and prior to or after the feature. Reading of designated scales will be official.

*Any issue that is discovered in pre-practice tech that is not fixed to officials' satisfaction by pre-qualifying tech will result in the loss of one qualifying lap.

NOTICES

1. The Rules and Regulations as set forth herein are designed to provide for the orderly conduct of CARS racing events and to establish minimum acceptable guidelines for such racing events sanctioned by the CARS Tour.
2. The rules herein shall govern the condition of all CARS Tour racing events and all participants are expected to abide by and comply with these rules and regulations.
3. No express or implied warranty of safety shall result from publications of/ or compliance with these or any other CARS Tour rules and regulations, or any CARS Tour directive or ruling by any CARS Tour official.
4. The CARS Tour director shall be empowered to make changes from any specification contained within these rules and regulations. Furthermore, he/she may impose further restrictions that, in his/her opinion, do not alter the minimum accepted standards.
5. No expressed or implied warranty of safety shall result from such alteration of specifications. All such interpretation and deviation is at the sole discretion of CARS Tour officials.
6. Regulations and specifications set forth herein are automatically amended by, but not limited to, technical bulletins and official entry blanks distributed by the Tour.
7. All specifications and regulations contained herein are subject to immediate change -without notice – as determined by the Tour Director.
8. The intent of these Rules and Regulations is to provide for competitive racing in all CARS Tour events.
9. CARS Tour reserves the right to change – without notice –schedule and event purses.
10. These rules are subject to amendment as CARS Tour officials deem necessary.

DEFINITION OF TERMS

Within these 2023 Rules and Regulations, the following terms are defined as:

1. "Office" shall mean the principal headquarters for the series, located at 136 Bridle Path Lane, Mooresville, NC 28117. Telephone: 704-662-9212.
2. "CARS Tour Officials" shall be employed and supervised by Championship Auto Racing Series.
3. "Member" shall mean all those individuals who have signed in to the "garage/pit/restricted area" at 2022 events.
4. "Event" shall refer to the CARS Tour sanctioned event, including, but not limited to, practice days and race days.
5. "Promoter" shall refer to such an individual, owner, president, principal, etc. -who represents the track at a CARS Tour sanctioned event.

GENERAL RULES AND REGISTRATION

The rules listed herein are effective from January 1,2023 until December 31, 2023. The following rules supersede all previous published rules for any CARS Tour class of racing.

Series Registration Procedure

1. The Annual 2023 Team/Owner registration will be \$200.00. This fee is non-refundable.
2. The Annual Driver Registration and License will be \$75.00 for 2023. This fee is non-refundable.
3. Single Event License in 2023 is \$100.00 for the Owner and \$25.00 for the Driver. The Single Event Licenses are good for registered event only and the fee may not be applied to annual registration fees.
4. It is mandatory for all competing drivers and cars to be registered for an event in which they participate.
5. Each team assumes responsibility for notification to CARS Tour of any change in address.
6. Each driver and team owner must complete tour registration forms prior to participation in any CARS event.
7. Car numbers are assigned by CARS Tour on an annual basis. CARS Tour officials will assign numbers after receipt of tour annual registration forms accompanied by the annual registration fee.

CARS MEMBERSHIP

General Rules

1. No intoxicating beverages or controlled substances are to be consumed before, during or after race events by anyone in the pit area. Owners assume full responsibility for actions of their crew members.
2. CARS Tour reserves the right to require alcohol and/or drug test to drivers, crew members, and car owners at any time during the course of any event.
3. Physical or verbal abuse of any CARS Tour Official will not be tolerated and is subject to fines and/or suspensions.
4. Race vehicles may only be driven by individuals with a valid annual CARS Series license. Licenses and hard cards are NOT TRANSFERABLE for use by any other team/individual than the one for whom the license/hard card was issued.
5. Interpretation of rules, procedures or scoring positions by CARS Tour shall be final, non-appealable, and not litigable.
6. Drivers, owners, and/or any other member of a crew shall have no claims against or cause of actions for damages, expenses, or otherwise against CARS Tour or its officials or promoter by reason of disqualification or damage to either car, driver, or both.
7. Race cars may be mechanically inspected by CARS Tour officials at any time.
8. Entry fees and pit gate fees shall be non-refundable. Entry fees must be paid prior to pit gate entrance.
9. Purse and owner championship points fund money, if any, will be distributed to owner of car in accordance with the 2023 W-9 form completed by the owner. Any changes to distribution of funds will be the owner's responsibility. Proper income tax information, including Federal ID numbers and/or social security numbers, must be on file before funds are distributed.
10. The decision on transporter parking -i.e., whether or not trucks will remain in the infield -will be determined on a race-by-race basis.
11. All rules and regulations in CARS Tour rule book are subject to interpretations by CARS Tour officials.

CARS LICENSES

License for Driver

1. All drivers must have a current and valid driver's license unless a waiver is obtained from CARS.
2. **All drivers must be at least 12 years of age. No exceptions.**
3. All drivers must be physically fit for racing. Tour director reserves right to request medical certification of fitness at his sole and absolute discretion.
4. **ALL** new drivers will be monitored by officials and their ability will be continuously evaluated. Cars Tour reserves the right to disapprove of any driver based on his/her ability to safely participate in the Series.
5. Owner will be held responsible for actions of all crew members.
6. CARS Tour reserves the right to revoke entry to anyone to any CARS Tour event for "just cause".

INSURANCE AND LIABILITY

Insurance

1. Insurance is made available to participants and/or persons entering the restricted area of a CARS Tour sanctioned event for accidental death or hospital, and/or medical bills. Such insurance is for a period normally associated with the completion of an event and for risks associated with participation in that event. Insurance shall be applied as secondary coverage ONLY after participant's primary coverage reaches its limits of coverage.
2. Persons admitted to the pits and other restricted areas of a CARS Tour race must obey all rules and regulations for that area as set forth by CARS Tour. Every individual admitted to any CAR Tour event must sign all releases as determined and/or required by CARS Series.

Waivers

1. Performance, Advertising & Promotion Release: That CARS Tour and it's assigns may use their name(s), picture (s), likeness(es) and performance(s) in any way, medium or material (including without limitation by and through television, radio, air wave, cable and satellite

broadcasts, film productions, videotape and audiotape reproductions, transmission over the internet, video games or other CARS Tour licenses products and public and private online services authorized by CARS Tour and the like, before, during and after the event, for promoting, advertising, recording or reporting the event or any other CARS Tour sanctioned event, and do hereby relinquish all rights thereto for these purposes, provided that the car owner and driver retain exclusive use of its name, picture and likeness in connections with product endorsements and the sale of products, services, concessions, and merchandise.

Injury Reports

1. Any injury involving any driver, owner, crew member, sponsor or any employee occurring on the racing premises, must be reported to the CARS Tour Technical Director or the medical personnel in charge, before leaving the premises (if said Member is able to make such a report). Otherwise, someone from the injured individual's crew should make CARS Tour Technical Director or the medical personnel in charge aware of said injury and to assist with the completion of an accident report by CARS Tour Tech Director.

SAFETY RESPONSIBILITIES

General Safety

1. All competitors are obligated to inspect the racing facilities, safety personnel and equipment, and conditions of the track on a continuing basis before, during, and after the event. Since the competitors are closer to the racing facilities, safety personnel and equipment, and conditions at the track on a continuous basis throughout the event than CARS Tour Officials or the Promoter, it is their obligation to inspect, observe and report to the Promoter promptly any inadequacy in the facilities, personnel, equipment, or conditions at the track. Competitors also are solely and directly responsible for the safety of their race cars and racing equipment and are obligated to perform their duties (whether as a car owner, driver, or crew member) in a manner designed to minimize to the degree possible the risk of injury to themselves and others. Neither the CARS Tour nor the Promoter can or will be responsible for the adequacy of a competitor's race car, racing equipment, or racing activity to accomplish this purpose.

IDENTIFICATION AND SERIES SPONSORS

CARS Tour reserves the right to approve or disapprove any advertising, sponsorship, message, or similar agreement in connection with any event. CARS Tour competitors agree to accept any CARS Tour decision in the event such judgment occurs.

Car Numbers and Driver Names

1. All cars are to have the number clearly readable on both doors at least 21" in height and 3" wide, roof numbers must be at least 24" high by 3" wide. Roof numbers should be readable from the left side of the car. All numbers must be decals only. No duct tape numbers will be allowed.
2. Primary car base color must be in high contrast to the number color to maximize visibility as well as to assist scorers.
3. No foil, aluminum or reflective type material permitted for use as car number.
4. Driver's names will be in letters easily read and on the roof over doors.
5. Numbers on replacement vehicles must be decals.
6. Letters being used as numbers must be visible in size and not be tape material.

Series Sponsor Decals

1. CARS Tour reserves the right to require tour sponsor decals on cars. No competing series decals will be allowed on cars.
2. CARS Tour reserves the right to place a series sponsor decal as the top of the windshield.
3. CARS Tour reserves the right to place a series sponsor decal on the side window between B and C post.
4. Decals must be adhered to the race car as outlined by CARS Tour.
5. CARS Tour reserves the area from the "A" Post forward and the "B" Post for the placement of series sponsors and contingency award sponsors decals.
6. Additionally, CARS Tour reserves the rocker panel area as well as the lower rear bumper area for series' sponsor decals.

RACE DAY PROCEDURES

Crew Chief/Driver/Spotter Meeting

1. CARS Tour officials will conduct a driver's meeting at each race. At this meeting, all new or special information that may differ from rule book will be announced and will be considered official. The following guidelines will apply for all driver meetings.
2. All drivers must sign in at the beginning of the meeting to ascertain their attendance at the meeting.
3. The driver, crew chief and spotter from each team are required to attend each driver's meeting.
4. Failure of driver, crew chief, or spotter to be present will result in a qualifying penalty of the loss of one (1) lap

Crew Chief Meeting

1. CARS Tour will conduct a crew chief meeting immediately after the pit gate opening at each event. Crew Chiefs will be advised of any abnormalities or peculiarities regarding the host track for the event and/or any differences in scheduling from normal activities.
2. All crew chiefs are required to attend. Failure for crew chief to attend will result in team losing practice time as determined by CARS Tour officials.

Qualifying Procedures

Qualifying procedures will vary by race and will be published in advance on the event entry form and event schedule. Formats include but may not be limited to:

1. Single Car Qualifying

- A. Qualifying position to be determined through random selection at meeting.
 - B. All cars must clear tech before qualifying. Any car or driver not ready to qualify at the assigned time will be issued a qualifying penalty.
 - C. Upon clearing tech, cars are considered impounded, and no more work is to be performed other than the adjustment of tire pressures. Any car that is worked on after tech will serve a qualifying penalty.
 - D. Competitors will single car qualify with a dead lap and either one (1) lap or two (2) lap time trials at the discretion of Series Director.
 - E. Pre-qualifying penalties will result in the competitor being a one (1) timed lap qualifier.
2. All tires to be used in the race event will be marked. Teams are required to start the race on the same tires on which they qualified. After qualifying, teams may not change a tire unless it is flat or has serious damage. Tire changes will be at the discretion of CARS Tour officials.
 3. After qualifying, cars may not leave impounded area or have any work performed on them unless instructed by Technical Director or his designate. All cars will qualify race ready according to rules herein unless otherwise discussed in crew chief meeting qualifying. Only cars that have sustained damage during qualifying, have a serious safety issue, or have had a major mechanical (i.e., blown engine) may be removed from the grid for repairs. In the event a team is granted permission to make an adjustment (**no parts may be removed or exchanged**), that car will be relegated to start at the rear of the field for the event and pay A FINE OF \$ 300. No work will be allowed on vehicles unless approved by Technical Director.
 4. No driver may attempt to qualify more than one (1) car in time trials. A qualified driver may change to a nonqualified car and start the race from the rear. A non-qualified driver may drive a qualified car if written permission is obtained from CARS Tour office prior to running of event. Permission will only be granted on a per event basis and only if circumstances warrant such permission. If approved, the car will start from the rear. Any change in drivers AFTER qualifying will result in that car going to the rear of the starting field.
 5. When two or more competitors have duplicate fast lap times the tie will be broken by the next fastest lap time (if both lap times or single lap qualification times are the same, then the tie will go to the car with the highest standing in owner points). If owner point standings do not prevail, then the driver setting the duplicate time first would start in front of the other.
 6. Unless otherwise directed by CARS Tour, the fastest qualifier will be given the choice of starting on the pole or taking the outside position in the front row. The fastest qualifier will be used as the control car for the start.
 7. **If qualifying is unable to be completed, the starting field will be determined by the combined times recorded in both practice sessions. If the second practice session was not held than the starting field will be determined by times from the first practice session. If practice and qualifying are both unable to be held, the starting field will be determined by CARS Tour owner point standings**

8. In postponed events where re-qualifying is specified, only the qualifying times established in re-qualifying will be certified as CARS Tour records.
9. The exact starting field for each event will be determined via the entry form. The standard 28 car starting field will be determined as follows:
 - A. Qualifying positions 1-26 will be determined according to the fastest 26 cars in qualifying.
 - B. The final two starting positions (27th-28th) will be reserved for the licensed competitor who has filed a timely entry for the event and who has the most 2022 owners' points who has not qualified for the event thru qualification or the "last chance race". For the first event of 2023, the final two starting positions will be determined by 2022 owner's points.

Race Procedures

1. All drivers must be on time to compete in the events for which they are scheduled. Any driver late for the autograph session and/or driver introductions, as determined by CARS Tour Officials, shall be relegated to the rear of the field prior to the start of the race.
2. No changes of driver at any time will be made without advance notification to CARS Tour Officials. If a driver change is made after qualifying, the car will start event at the rear of the field. When the race is in progress, driver changes must be made in pits only.
3. Any qualified car may be driven in any event by a registered CARS Tour licensed driver. However, the driver who starts the car in the race will be awarded driver points for the event.
4. CARS Tour Officials will use flags, as set forth in this section, for the purpose of providing driver with information. Officials may use light signals in addition to or in lieu of flags. The procedure for use of flags and/or lights by Series officials may vary for individual series or races.
5. The initial start and all restarts will be double file. On the initial start and all restarts, cars must maintain their positions as determined by CARS Tour officials until they have reached the designated starting point on the track as covered in the drivers meeting. In the event of a caution on the first lap of the race, the field will be restarted as per the original line up with the exception of the cars that were the reason for the caution---- they will restart at the rear of the field. On restarts, the race will resume immediately when the green flag is displayed. CARS Tour officials may make a special ruling on starts or restarts for any race (i.e., following a red flag, the yellow flag will constitute an official restart of the race).
6. All starts and restarts shall be made at a designated area on the track and made known to the drivers in the pre-race meeting.
7. The blue flag with a diagonal yellow stripe signifies that faster traffic is overtaking the cars being signaled. Cars being given this flag must yield to overtaking traffic as directed by CARS Tour Officials.
8. The yellow flag signifies caution and this flag will be given to the first car passing the starter immediately following the occurrence of the cause for caution. All cars receiving the yellow flag or light shall slow down to a cautious pace, hold their position, and form a single line behind the lead car. A pit entry flagman stationed at the entry to pit road will wave a red flag that signifies that pit road is closed. Pit road entry procedures may vary from track to track and will be discussed at the drivers meeting prior to the event. When the yellow flag and/or caution lights are displayed, all competitors will cease racing and will not pass as long as all cars maintain a reasonable speed. Any car entering the pits prior to the pit road being deemed "open" by Race Control shall restart the race at the rear of the longest line of cars. Cars will restart in the order they were running at the completion of the last green flag lap.
9. Cars returning to the race track from the pits while the yellow flag is out must wait for the rear of the field in the line behind the pace car, or as otherwise directed by CARS Tour officials.
10. The Series Director, at drivers meeting, shall announce the number of consecutive green flag laps to be completed prior to a competition caution. This number of consecutive laps may vary with each event. If the race goes said amount of consecutive green flag laps without a natural occurring caution, a competition caution will occur. The only time this will not occur is if the "said consecutive green flag lap" falls inside twenty-five (25) laps to go of the total race distance.
11. No car may pass the pace car unless directed to do so by Race Director. Any car passing the pace car unapproved will be assessed a one (1) lap penalty.
 - A. During a given caution period only one (1) car is eligible for the "Lucky Dog" per caution period. That car may be any number of laps

down to the leader, but the Lucky Dog will go to the first eligible car. The Lucky Dog CAN pit during this caution period. This car may only pass the pace car when directed to do so by the Race Director. If the first eligible car was part of the incident on the track which resulted in the current caution period, this car will forfeit their privilege and this privilege will not be passed on to any other car during the same caution period. Once the car passes the pace car, that car must restart at the tail end of the longest line. The Lucky Dog pass will not be offered if the restart is within last ten (10) laps of the race.

- B. Vehicles on the rear of the lead lap, in front of the race leader, and immediately behind the pace car may be directed to pass the pace car and proceed to the rear of the longest line. These vehicles may not advance until directed by the race director. Additionally, these vehicles are not eligible to pit after advancing the pace car.
12. Pit attendants and crew members shall not go on the race track for ANY reason. The only time drivers or cars may receive service is when they are completely stopped in the pits. Any person venturing onto the track at any time during the race may be fined \$300 and face a possible suspension.
 13. The red/yellow combination of flag means racing must stop immediately regardless of the position of the cars on the track. Under red/yellow situation cars may enter pits, as safety allows, for crews to work on their cars, but only after the officials have given them permission to do so. All teams that work on their car under red/yellow situation must restart at the tail of the field regardless of their previous position.
 14. The red flag means that the race must be stopped immediately regardless of the position of the cars on the track. The red flag shall be used if, in the opinion of CARS Tour officials, the track is unsafe to continue to race or a prolonged caution period is anticipated. Cars should be brought to a stop in an area designated by CARS Tour officials.
 - A. No repairs or service of any nature will be permitted when the race is halted due to a red flag. All work must stop on any car in the pits when the red flag is displayed and work cannot be resumed until the race is placed under the yellow caution flag. Teams that work on a race car while under red flag will be assessed a two (2) lap penalty.
 15. The black flag means for the competitor to go to the pits immediately and report to the CARS official at the driver's pit. It does not mean automatic disqualification. If the driver does not obey the black flag directive for five (5) consecutive laps, the driver will then be given the black flag with a white cross to inform the driver that scoring of his or her car has been discontinued until further notice.
 16. In lieu of a black flag, CARS Tour officials may use a blackboard or black flag number indicator in full view of the competitor on which the number of the car being black flagged will be shown.
 17. When the white flag only is displayed, it means the leader has started his or her last lap. If the yellow flag is displayed during the white flag lap, all cars will cease racing and slow to a cautious speed. The race will not end under caution. The race will end with a green, white, checkered finish. The process will be repeated until the leader receives the checkered flag.
 18. A car may not receive any assistance after the white flag has been displayed except a car being pushed on pit road. Violation will result in the car not being scored for that lap.
 19. When the checkered flag is displayed, it means the race is completed. When the required race distance has been completed by the lead car, the race will be declared "official" regardless of any flag being displayed.
 20. When the checkered flag is given to the leader, the balance of the field receives the checkered flag in the same lap. Finishing positions will be paid according to most laps traveled in the least time, whether the car is still running or not.
 21. The winner of the event will bring his/her car to the start/finish line (or victory circle) while the second and third place finishers will drive directly to the tech facility for post-race inspection. All others will enter their pit area immediately after receiving the checkered flag.
 22. Special flags may be used at the discretion of CARS Tour officials but must be explained to all drivers before the race starts.
 23. Teams that work on a race car while on the racing surface while under yellow or red conditions will be disqualified.
 24. No car will be permitted to continue in competition if, in the opinion of the Race Director, the car is a hazard to the other cars in the event.
 25. Cars must take the checkered flag to win. Any race rained out or stopped because of curfew at one lap past halfway of the event will be considered a completed race.
 26. Any driver who does not obey the flag rules may receive a fine and/or lap (s) or time penalty.

27. Any competitor who causes or attempts to cause a yellow flag by stopping his/her car or throwing debris on the racing surface will be assessed a one (1) lap penalty and restart the race as the very last car to take the green flag. Any car that stops on the racing surface during any pace laps must drop to the rear of the field.
- A. Each team is responsible to ensure the Technical Director has the teams' current frequency.
 - B. Each CARS Tour team will be responsible for providing a spotter, in a designated area for spotters, for their vehicle at any time the vehicle is on the track either in practice, qualifying, or racing. This spotter **MUST** be capable of monitoring race control frequency at all times (even when the team's primary frequency is in use) and be capable of communicating messages to his/her driver as directed by CARS Race Control. All Spotters must attend the 'driver, crew chief, spotters' meetings. Failure to attend the meeting(s) will result in a car becoming a "one (1) lap qualifier"

"IN-RACE" Pit Stop Procedures

1. When following the pace car under a caution flag, driver must maintain their position in relation to other cars in the field or as otherwise directed by tour officials. Pit road opening/closing shall be controlled by the use of lights or flags. Cars choosing to pit must drop down to enter the pits at entrance/apron of pit road. Pit procedures for each event will be determined in CARS Tour driver/crew chief meeting prior to the event
2. When pit stops are made for a tire change, all lug nuts must be fully tightened before the car leaves the assigned pit area. If the pit road official detects a violation, the car must return to its assigned pit area for inspection.
3. Any competitor who goes behind the wall or to the infield for repairs during an event will be considered retired from the race.
4. Only one (1) jack and two (2) wrenches (air or manual) can be used for any pit stop involving tire changes. The same jack must be used when tires are changed on the left and right side during the same pit stop. In the event a car falls off a jack, a second jack can be used on the same side to facilitate use of the first jack.
5. Cars must be completely in their respective pit box during pit stops (as space permits).
6. Race cars exiting pit road under caution flag will not be allowed to blend into traffic but must fall into line behind the last car on the track. **DO NOT ADVANCE**. Cars which advance will be moved to the rear.
7. Cars entering on pit road must not exceed pace car speed. The pace car will maintain "Pit Road Speed" during warm up laps. Drivers will note their gear and tachometer at this time and will not exceed this speed at any time while on pit road. Speeding on pit road will be enforced at all times. Cars speeding on pit road will be moved to the rear of the field.
8. The tour reserves the right to change, alter, or add to pit stop rules at any event. In the event rule changes are implemented at the race track, such changes will be discussed at the driver's meeting.
9. Pit assignments will be determined through CARS Tour officials as early as possible and will be determined on a race-by-race basis as pit conditions dictate.
10. **MANDATORY:** Teams must have a minimum 10# fully charged fire extinguisher in their pit area. Any team found in violation will be fined \$100 and will start in the rear.
11. No smoking within 15 feet of pit stalls. Failure to comply will incur a fine of \$100 per incident.

Timing and Scoring

1. The tour official designated by CARS to be the Director of Scoring for an event is totally responsible for scoring the event. The decisions of the Scoring Director, with respect to timing and scoring, are final unless the Scoring Director elects to request a re-check by the CARS Tour office or when the Scoring Director is asked by a competitor who has competed in the event to submit a request for such recheck to tour office.
2. When possible, the UNOFFICIAL finish will be posted at the command center within one (1) hour of the checkered flag.
3. A scoring protest must be written and accompanied by a \$250.00 NON-REFUNDABLE service fee and be presented to the Series Director or Scoring Director within one (1) hour of the posted finish. No protests will be accepted after that time.
4. If possible, scoring rechecks will be done at the track. If it is an extensive recheck, the office will have five (5) working days to recheck the scoring and post an official finish. Until that time, the finish is not considered official. Decisions of the CARS Tour office on a scoring re-

check are final, non-appealable and non-litigable.

Rain Delay and Cancellation

1. In the event that weather, or any other unforeseen situation, would prohibit the CARS Tour event to be held on the advertised date, the event will be scheduled for next day, if possible. If the next day is not an option, event will be re-scheduled on a later date or cancelled altogether. This decision will be at the sole discretion of the Series Director.
2. There shall be no refunds for grandstand tickets, entry fees or pit passes. All grandstand tickets, entry fees and pit passes will be honored at the next scheduled CARS Tour.
3. Tour officials reserve the right to change these procedures as applied to that particular situation, as well as reserve the right to cancel the event altogether.

CONDUCT & PENALTIES

Conduct Violations

1. If a CARS Tour official in his/her sole discretion determines an act of commission or omission by a CARS Tour member that constitutes a violation of the CARS Tour Series Rules or that is detrimental to auto racing or to the CARS Tour, and if the tour official in his/her sole and absolute discretion determines that the act of commission or omission is sufficiently serious to warrant the imposition of a penalty, the Official shall report the violation in written detail to the tour director as soon as practicable, and shall recommend an appropriate penalty. The tour director shall consider the report and shall conduct whatever additional inquiry deemed appropriate under the circumstances. After concluding the inquiry, the tour director shall determine whether disciplinary action is appropriate, and if so, what disciplinary action should be taken. The Member shall be informed of the determination, and if disciplinary action is imposed, the tour director shall issue a penalty notice to the Member specifying the violation, a brief statement of the circumstances of the violation, and the penalty imposed.
2. If the act of commission/omission of a Member is determined by a CARS Tour official to constitute a threat to the orderly conduct of the race, that official may take temporary emergency action against the Member. Such emergency action may include ejection from the racing premises, temporary or permanent suspension or any other action designed to remove the threat created by the Member. Examples of conduct warranting such emergency action include, but are not limited to, the consumption of alcoholic beverages or drugs before, during or after an event, the use of illegal drugs at any time, fighting, reckless driving, and failure to obey the black flag or any other directive of an official. The CARS official shall report the Member's conduct to the tour director as soon as practical, and thereafter the procedure set forth above shall apply. The emergency action shall remain in effect until the decision of the Series Director is made which shall be final.
3. Fines shall be paid to CARS Tour office in Mooresville, NC, promptly after receipt of a penalty notice. Failure to pay promptly will result in suspension. All unpaid fines of a Member may be collected by the Series by deducting the amount from the purse earnings of the Member, or if the Member is not an owner, from the purse earnings of the owner with whom the Member was associated at the time of the conduct that gave rise to the penalty notice. All fines will be paid before entry for the next event.

Penalties

1. Penalties for violation of CARS Tour Rules are determined by the gravity of the violation and its effects on fairness of competition, the orderly conduct of the event, and the interests of stock car racing and the Series. Such penalties may include, but are not limited to, disqualification, suspension, fines and/or loss of points. A suspension may be permanent or for a specified or indefinite period of time. The tour director may use the following as guidelines for the imposition of penalties in the situations described below, but these guidelines shall not limit the authority of the Director.
 - A. Any Member who performs an act or participated in actions deemed by CARS Tour officials as detrimental to automobile racing or to the CARS Tour, a fine of at least \$500.00, suspension of those persons involved in the act, and/or loss of championship points
 - B. Any owner whose car is found with a traction control device (working or not) will be suspended indefinitely.
 - C. Any Member who signs the tour release sheet or competitor pit permit for anyone else; a fine of at least \$500.00 and suspension.
 - D. Any member who assaults or threatens to do bodily harm to any CARS official or persons serving under their direction; a minimum fine of \$ 1000.00, suspension, and/or loss of championship points.
 - E. Any Member who, while participating in a Series sanctioned event, partakes of any alcoholic beverage, stimulating, depressing or tranquilizing drugs, or is otherwise under the influence of alcohol or drugs, will be suspended indefinitely.
 - F. Any Member(s) who enters another competitor's pit area and instigates a physical confrontation will be fined \$500 with a possible suspension.
 - G. Any Member who commits an assault with a weapon of any description in the pits, on the track or on any of the track premises; a minimum fine of \$5000.00, a suspension and/or loss of championship points.

- H. Any Member who permits a car to be driven in any CARS Tour sanctioned event by an unlicensed person, or who fail to notify CARS officials of any change of driver during a race may be fined up to \$1000.00 and/or suspended.
- I. In an event where the CARS officials mandate post-race inspection of a car that has competed in the event and that car is taken from the racing premises without permission of a CARS official, the car will be disqualified.
- J. Any member who refuses to tear down a car for inspection when requested to do so by the CARS official; a fine of not less than \$1,000.00, and/or disqualification, and/or loss of championship points, and/or definite or indefinite suspension from the Series.
- K. Any determination by CARS officials that parts and/or equipment used in the event do not conform to CARS Tour rules or have not been approved by the CARS Tour prior to the event or which are not required for the normal functional operations of the race car or safety items which have been altered to detract from or compromise their integrity or effectiveness, disallowance of qualifying times, withdrawal of opportunity to qualify for the event, and/or fine, and/or suspension from CARS Tour.
- L. Any member failing to surrender to CARS Tour any part and/or equipment found during an inspection, a fine and/or loss of finishing positions in the event, and/or loss of championship points, and/or definite or indefinite suspension from the Series.
- M. Any concealed pressure type containers: feed lines or actuating mechanism when found in the car or on the person of a competitor even if inoperable, a fine of not less than \$1000.00, and/or loss of championship points, and/or definite or indefinite suspension from the CARS Tour.
- N. Any modification that permits the lowering of a race car while in competition, including but not limited to the wedging of springs and shock absorbers or any modification that permits the lowering of a race car while in competition, or any car that is found to be under the specified height requirement after the completion of time trials or the race, disallowance of qualifying time, and/or loss of championship points, a fine, and/or lap (s) or time penalty.
- O. Any violation of fuel cell or fuel cell container specifications; a fine, and/or loss of championship points, and/or definite or indefinite suspension from CARS Tour.
- P. Any competitor found using, in his or her car, automated electronic recording devices, on board computers, and the likes, which have not been approved by CARS Tour prior to the event; a fine or \$1000.00, and/or loss of championship points, and/or definite or indefinite suspension from the CARS Tour Series.
- Q. Use of altered fuel or fuel other than the official fuel at the event, a fine, and/or loss of finishing position, championship points, and/or definite or indefinite suspension from CARS. Failure to cooperate with tour officials in obtaining fuel samples at any time during an event will subject the car to disqualification and will subject the crew chief and/or car owner to additional penalties deemed appropriate by Series officials.
- R. Use of any tire or tires that have been altered by unauthorized treatment to the tread area disallowance of qualifying times, withdrawal of the opportunity to qualify for the event, and/or minimum fine of \$500.00 per tire, and/or loss of finishing position in the event, and/or suspension from the tour.
- S. Any car starting the race on tires other than its qualifying tires, a fine and/or loss of championship points, and/or definite or indefinite suspension from CARS Tour.
- T. Any team found using any tire(s) that has not been impounded for that event will be assessed a one (1) lap penalty at the conclusion of the event.

Race & Pit Procedure Penalties

1. "To Rear of Longest Line"
 - A. Speeding on pit road
 - B. Dropping down too soon or late for pits
 - C. Pit outside of designated area
 - D. Enter pits early
 - E. "Reckless" driving
2. "Stop & Go" ----under green flag.
 - A. Too fast down pit road under green
 - B. Failure to line up in correct position with position gain or restart in wrong line with position gain
 - C. Running stop sign
3. "Lap/Laps Penalty"
 - A. Unauthorized pass of pace car

- B. Failure to obey flags
 - C. Intentional yellow
 - D. "Rough" driving/retaliation
 - E. Work on car during red flag
4. "Black Flag/D.Q'/Other"
 - A. Working on car on the racing surface
 - B. Ignore black flag for 3 laps
 - C. Car aided on white flag lap
 - D. FLAGRANT "rough" driving.

CARS Tour INSPECTIONS Inspections

1. All vehicles will pass through technical inspection before qualifying for all CARS events. All inspections will be performed as designated by Technical Director and may vary from race to race.
 - A. All general safety as well as technical and general appearance guidelines must be adhered to before vehicle will be allowed to compete.

Post-Race Inspections & Penalties

1. There will be no tolerance to rules unless specified. Failure to comply with rules MAY result in disqualification from qualifying position, finishing position or disqualification from event entirely
2. Series' weighing, measuring, and testing devices as well as procedures used by CARS Tour technical officials are the standards which determine a vehicles compliance with tour rules and regulations. No other equipment or device may be used unless approved by CARS Tour Technical Director.
3. The decision on rules infractions during pre-qualifying or post-race technical inspections as imposed by the Technical Director shall be final and non-appealable.

Non-Conforming Parts

1. CARS reserve the right to confiscate any non-conforming and/or unapproved part (s).
2. Any use of components utilizing mercury for the enhancement of performance shall be deemed to render the vehicle ineligible to compete in the Series and such violation of law shall be reported to the appropriate authorities. Any clean-up and fines will be the car owner's responsibility.

APPEALS

1. The CARS Tour Director or his designate shall have final authority for any and all decisions regarding the CARS Series.

Appeals Procedure

1. A car owner may file an appeal against a penalty imposed by the CARS Tour Director provided that the individual submits an "Intent to Appeal" letter to the Series Director within five (5) days of the penalty notice.
2. Appeals must be in writing and accompanied by the non-refundable appeal fee of \$500.00.
3. The CARS Tour Director shall be responsible for the orderly disposal of such appeals by appointing an Appeals Board. The Board shall be comprised of members or officials at discretion of CARS Tour Director. The time and date of the appeals hearing will be as soon as possible at the Series Director's sole and absolute discretion.
4. Three members shall constitute a quorum for the Appeals Board.
5. The Board shall establish procedures for hearing the appeal and shall not be bound by technical or formal rules of evidence or procedure. The hearing will be conducted in the manner best suited to the relevant facts.
6. Cost of the proceedings shall be at the expense of the CARS Tour. However, if the Board determines that the appeal may have been instituted without merit, the cost for such hearing will be the responsibility of the Member who instituted the charge.
7. The appellant may not file an appeal against the judgment issued by the Board of Appeals.
8. The CARS Tour Board of Appeals, the Director, nor any other body shall order an event to be rerun.
9. The Series shall have the right to publish the judgment of the tour Board of Appeals and to use the names involved. The persons or teams

so named shall have no recourse to act against these parties or the publisher of the judgment.

10. Race procedure calls are considered judgment calls and shall be non-appealable and non-litigable.

Owner/Driver Championship Points

System

1st	33	19 th	14
2nd	31	20 th	13
3rd	30	21 st	12
4th	29	22 nd	11
5th	28	23 rd	10
6th	27	24 th	9
7th	26	25 th	8
8th	25	26 th	7
9th	24	27 th	6
10 th	23	28 th	5
11 th	22	DNQ	2
12 th	21		
13 th	20		
14 th	19		
15 th	18		
16 th	17		
17 th	16		
18 th	15		

*All cars that do not qualify for feature event will receive two (2) championship points if completed a qualifying attempt.

Bonus Points Program

1. Lap leader -one (1) point awarded to each driver who leads at least one lap.
2. Pole - Two (2) point awarded to winner of pole at each event **if** qualifying is completed.
3. Leader of most laps - one (1) event point.

Year-End Series Point System

1. Car with the most 2023 wins will receive a two (2) point bonus at year's end.
2. Car with most 2023 poles will receive a one (1) point bonus in the final point standings.
3. Drivers and Owners championship shall be determined by driver/owner earning most points in events during the 2023 season plus any bonus points earned. In case of tie, Champion will be determined by most wins, most seconds, etc., until tie is broken.
4. All other point positions ending in a tie will be handled in the same manner.

2023 SERIES TECHNICAL DATA

Eligible Body Guidelines

2007-2019 AR BODIES/FIVE STAR BODIES/NEXT GEN FIVE STAR BODIES APPROVED MODELS

1. All competing cars will be full-sized stock American manufactured passenger car composite bodies as approved by CARS and the NASCAR Late Model Stock guidelines as well as the approved suppliers specifications manual (AR Bodies/Five Star

Bodies). Refer to Appendix #1 for diagram and body dimensions. No steel bodies allowed.

2. No under car panning or unused holes (open) in body.
3. Rear spoiler must measure 60" wide by 6.5" tall and made of Lexan or aluminum and centered on chassis. No forward braces allowed. Must be between 50-60 degrees in angle.
4. The air box between the radiator and the nose may not be any wider than the radiator. No air deflectors of any kind are permitted. All air for blowers or coolers must be pulled from nose. Air blown to brake rotors only---not tires or tire beads.
5. Maximum tread width of 66" measured from outside to outside of wheels at spindle height.

Weight

1. Base weight shall be a minimum of 2800 lbs.
2. Left side weight shall be a **MAXIMUM** of 58% of the total car weight.

Engines

1. Unaltered GM #88958604 with factory seals only will receive a 25 lb. weigh break.
2. GM #88958604 / 88869604 with the following updates only, GM Cam #24502586, 1.6 rocker arms, Comp Cam valve springs #941-16, Champ oil pan #CP106LTRB and Balancer.
3. Ford #M06007-D347-SR with 1.5 rockers.
4. McGunegill Ford #425LM with 1.5 rockers.
5. Crate engines may be refreshed but must retain all manufacturers' specifications unless specified. No reground cams. Maximum compression on all engines 10.0. Re-built engines must have seals from a re-builder on the S.E.A.L. approved list or carry a 75 lb. penalty. Seals on all engines must remain in place and be unaltered.
6. Only the top five drivers finishing a race, their crew chief, or car owner may protest a crate engine from a driver finishing the race ahead of the protesting Driver. The protest will be limited to one car and must be made within ten (10) minutes after completion of the feature event with the cash only protest fee to the Tech Director. The protest fee will be \$1500.00. The protest fee will not be accepted should CARS Officials determine the protest fee has been made on someone else behalf or the fee is from more than one party. Failure to accept protest will result in the driver forfeiting all purse winnings. The driver must also pay a \$1000.00 fine prior to being allowed to compete again on CARS 2022 Racing Season.

CARS TOUR RULE ONLY

Engines not needing to be rebuilt may be placed on a dyno for inspection by a S.E.A.L. approved rebuilder. If engine performs in the satisfactory range, the S.E.A.L. rebuilder will install a "CARS Tour" seal. Reminder – the CARS Tour seal will **not** be accepted at any other track or series. **At the time of this printing the following engine builders in our area are S.E.A.L. approved: PME Engines, Charlie Long Engines, and RW Engines**

Carburetor/Spacer/Air Cleaner

1. Holly 650 HP 4150-80541 four-barrel with no alterations allowed.
2. Body of carburetor – no polishing, grinding, or drilling of holes permitted. No paint or any other type of coating other than from carburetor manufacturer allowed inside or outside of carburetor.
3. Any attempt to pull outside air other than down through venturis is not permitted.
4. A minimum of two return springs is required. Throttle stops recommended.
5. Unaltered GM #88958604 / 88869604 may use a maximum height 1" aluminum open or four (4) hole type spacer only with 1 paper gasket per side not to exceed .065" in thickness.
6. Engine options 2, 3, and 4 above must be equipped with a one (1) piece ½ inch thick adjustable base plate produced by Allstar Performance PN#ALL26180 equipped with four (4) 1.250 base plate inserts PN#ALL26186 produced by Allstar Performance with one (1) paper gasket per side not to exceed .065" in thickness. Base plates and inserts must not be altered.
7. Air cleaner maximum diameter of 16 inches and cannot be removed at any time, may not be sprayed, or soaked within a type of chemical or liquid.
8. Nothing may direct or control the flow of air inside the air cleaner housing except the air cleaner element.
9. No heat shields or any other type of hot air deflection device or airflow deflection device allowed in engine compartment.

Engine Placement

1. Measured from the center of #1 spark plug hole to the center of the top ball joint with a ¼” tolerance is 4 inches.
2. Engine must be in center of frame with 1” tolerance.
3. Center of crankshaft to ground clearance 10”.

Exhaust

1. Any type of single flange steel tubular header will be permitted, NO INCONEL permitted. Exhaust system must exit behind driver. If exhaust exits through the door, installation must include an exhaust flange that is mounted flush to the door and no more than ½” gap around pipe.
2. A muffler must be used and installed in a configuration that will suppress exhaust noise to a maximum of 99 db’s at 100 feet. The series will conduct random testing of exhaust noise. A penalty of 10 lbs for every point above 99 db’s will be enforced. Any car that is consistently tested above 99 db’s will receive additional penalties up to and including disqualification.

Cooling System

1. All cars must have catch can or hose to exit at windshield.
2. Water only must be used in cooling system. Any additive to water i.e., water wetter, must first be approved by a CARS Official. Any driver found using unapproved coolants must pay a \$100 fine before driver can compete at event.
3. The duct work between the nose and the radiator may be no wider than 29” and can not be carbon fiber. The standard opening for the grill screen area, as approved for manufacture’s production, must be maintained at all times. Only said manufacturer’s standard mesh screen may be used for the radiator opening in the nose.
4. Tape may not be used anywhere on the car to control the flow of air or seal/secure seams between body panels except front grill screen and front brake ducts unless approved for repairs.
5. Titanium is not allowed for use in any way on the race car unless noted.
6. No cool down units, pumps, or exotic fans are permitted.

Transmission/Clutch

1. Must have transmission with at least two forward and one reverse working gear. **BERT, BRINN, WINTERS RAPTOR (PART #60200 TWO SPEED) OR MAGNUS sealed “MUNCIE STYLE”(PART #13100 TWO SPEED) transmissions will receive a 25# weight break.** Jerico type transmissions permitted.
2. No Rankin or direct drive type, quick-change, or automatic transmissions permitted.
3. Multiple disc clutches with steel floaters and pressure plates permitted, with a 5 ½” in diameter minimum.
4. No carbon fiber clutches are permitted.
5. Clutches found to not meet this definition will be deemed illegal.
6. Clutch housing assembly or cover may be made of steel or aluminum.

Spindles

1. Aftermarket, homemade, and ¾ ton steel spindles are permitted with the exception of approved Coleman Spindle.

Brakes/Brake Cooling

1. Front and rear disc brakes are mandatory.
2. Brake fluid circulators are permitted.
3. Liquid or gas cooling not permitted.
4. Only cast steel rotors will be permitted.
5. No carbon fiber, fiberglass, or titanium brake parts permitted.
6. All air intakes must be routed either from the nose of vehicle or air box.
7. Two hoses per brake, with a maximum 3” flexible hose to the brake.
8. **NO fans, ducts, or hoses to rear brakes.**

Ignition

1. One Crane/Fast Ignition part #6000-6701 OR Daytona Sensors #CD1 SPEC Racing only as produced or mounted on right side of car dials pointed out the passenger side on original plate. The mag positive and negative wiring shall be a maximum length of 62 inches. Must remain uncut or spliced and on top of dash in clear view. Maximum of 6300-RPM for Fords and 6500-RPM for Chevy. This set up may be swapped out by Officials at any time.

2. The Nelson Specialties/SRL harness or Quick Car PN #50-2053 spec wiring harness is mandatory. All wiring must be sealed, no unplugged wiring.
3. One battery permitted. Maximum 16 volt and mounted securely outside of driver's compartment.
4. NO Traction Control Devices of any kind are permitted. If any traction control device is found, the driver and owner will be disqualified from the event and the car will be confiscated until a \$15000.00 fine is paid. Additionally, the driver and owner will receive a lifetime ban from all CARS events.

Wheels/Tires

1. Only a 10" Racing steel wheels, steel studs, and steel lug nuts are permitted and must have decal with correct car number labeled.
2. No air bleeders permitted. NO BLOWERS OR HOSES WILL BE PERMITTED TO BLOW AIR ON TIRE OR WHEEL.
3. HOOSIER DESIGNATED TIRE ONLY.
4. No soaking or altering of tire in any manor allowed. Drivers soaking or altering tires will forfeit all purse monies and points for the event. Additionally, driver will be fined \$1000.00 and banned from future CARS events until fine is paid. Any illegal tire, in the judgement of CARS Officials, will be confiscated.
5. Maximum tread width allowed is 66 inches – No tolerance.

TIRE PURCHASE RESTRICTION

Teams will be limited to a maximum purchase of eight (8) tires per event. (Four for practice and four for race). ALL tires must be purchased through MTP Tire – The Official CARS Tour Tire Vendor. These tires will be branded with a CARS seal. Any team practicing on unbranded tires will be penalized one (1) Qualifying lap. All cars will start race on four (4) sticker CARS branded tires.

Shocks/Springs

1. One shock per wheel. Shocks must be only mechanical in nature and no part of suspension or shock may utilize electricity.
2. Maximum one coil spring and one bump spring associated with each wheel.
3. Steel Coil over bucket type springs permitted only. No titanium, air, or carbon fiber.

Rear-End/Drive Shaft

1. Quick change and open tube rear ends are permitted. Cars must utilize a locked rear end with a spool **and a minimum ring gear of 8"**
2. No independent rear suspension is permitted.
3. No fifth (5th) coil, torque arm, or lift bar suspensions will be permitted. No birdcage set-ups of any kind (3 or 4 link). Trailing arms must be mounted to rear end in a solid fashion (heim allowed) and no part of the trailing arm mounting may freely rotate around the rear end.
4. All parts of rear suspension must be solid, one-piece construction with no moving parts with one heim at each end. All mounts for trailing arms, third links and track bars, must also be solid and may not have the ability to move. The wheelbase difference from left to right may NOT exceed ½ inch.
5. Only Steel or Aluminum drive shafts are permitted and must be painted white or silver. No carbon fiber wrapped in aluminum drive shafts are permitted.
6. Minimum of one (1) 360-degree drive shaft loop. Must be 1" x ½" steel.

Fuel System/Cell

1. Fuel must be unaltered. Fuel samples may be taken at any time and tested. Alcohol, nitromethane, nitrous oxide, or other additives not permitted. Use of such substances or additives will result in immediate D.Q.
2. Manual block mounted stock type fuel pumps only. No electric fuel pumps.
3. No icing, Freon type chemicals or refrigerated may be used in or near the fuel system or engine compartment.
4. Fuel cell mandatory, maximum 22 gallons vented with maximum 1 inch vent to outside left rear of body. No "U" Shaped Fuel Cells or non-standard shaped fuel cells. OBERG Fuel Valve #SV-0828 or SRI #FFF-FSV is mandatory.
5. Fuel cell must have a minimum of two (made of 1-inch square tubing) protection braces wrapping around fuel cell from front, underneath, and to back of cell. Additionally, a rear protection bar of 1.75" tubing extending below the rear of frame and at least ½" below the bottom of fuel cell to cover the width of the fuel cell. Minimum ground-to-fuel cell shall be 8 inches.
6. Cars must have a minimum 1/8" steel plate, or similar strength aluminum plate, between fuel cell and rear end. A similar plate at the rear end windows

Body

1. Refer to CURRENT ABC Rulebook for all body rules and all panels must have ABC stickers. **The Five Star Next Gen body has been approved for competition. The AR Revolution body is NOT permitted.**
2. Minimum/Maximum Nose Height will be as follows: Minimum nose, body, and frame height is 4 inches and a maximum of 8 inches. (While in tech for the purposes of tech inspection).
3. At all times, **the original ABC bodies** "A" measurement must maintain a minimum length of 11 ½ inches and 20 inches is the minimum length allowed for the nose measured from the bottom leading edge at center and up to the hood seam. Only ABC manufacturer's standard grill screens may be used for the radiator opening in the nose.
4. No panels allowed extending top edge of doors. The car body must be acceptable to CARS Officials at all times. No car will be allowed to start a race without a full body.
5. A-Pillar vent windows may only have 1 inch of straight-line deflection. The surface must be smooth and must not have bead rolls or breaks.
6. Front nose valance may only be a SINGLE layer and a 3/16" thick maximum and maximum of 3 inches.
7. Window tint of any kind is not permitted on windows or spoilers.
8. Only one (1) opening (total) in the rear ¼ windows will be permitted and that is for the air to cool drivers helmet. All other openings must be sealed/taped off.
9. **Tape may be used on the front grill and rear spoiler---ONLY!!**

Interior

1. Interiors must be steel or aluminum only and shield driver from ground, engine compartment, and fuel cell area. Firewall must be no less than 24-gauge metal and fully seal driver from engine compartment.
2. Car may have an installed dash panel with optional gauges. No digital dashed are permitted.
3. No cell phones, watches, or Bluetooth devices will be permitted at any time in racing vehicle. Any This will lead to an automatic disqualification.
4. No in-car timing devices during competition. No driver adjustments in car other than one brake bias adjuster is allowed.
5. ON-OFF switch must be located on dash within easy access of driver as well as access from outside left window opening. ON-OFF positions must be clearly marked.
6. Quick release steering wheel is mandatory. Center top section steering post must be padded with at least 2 inches of padding material.
7. All roll bars surrounding driver must be padded. Padding must be acceptable to CARS officials.
8. **SFI rated racing seat is highly recommended. Seat must attach to roll cage, not to floor.**
9. SFI/FIA 5-Point harness and window net requires; net must release at top left former. No older than five years old.
10. Rear view mirror permitted inside of car only.
11. Approved SFI/FIA helmet and fire suit, shoes, and gloves required any time vehicle is on racing surface. Nomex head sock highly recommended.
12. SFI/FIA Head and Neck restraint will be mandatory.
13. Bumper bars and right-side door bars must be a minimum of .065 x 1 ¼" steel tubing.
14. No Data Acquisition equipment/wiring is allowed in the car on officially recognized practice or race days.
15. Only one open hole in the ¼ window nagaducts. This opening is for supplying air to a helmet cooler, or other specific item only. All other openings in the nagaducts (if any) must be taped shut.

Frames

1. Straight rail, perimeter, and OEM front clip frames are permitted.
2. No chassis adjustment from inside car except for brakes.
3. Frame and roll cage, including weight box, must be inside of left front and left rear tires.
4. No types of under-body air deflectors or panning allowed. All air for brake blowers or coolers in the engine compartment must be pulled through the nose or the radiator air box. Air may not be blown or forced onto the tire or bead; air may only be directed to the brake rotors. No reverse naca-ducts.
5. No under car panning outside of the width of the frame rails no further than drivers' tub, front or rear, at the bottom of the frame. Lead cannot be used as panning or aero advantage.
6. Maximum drivers tub length is 52 ½" and the maximum width of frame is 53 ½" on any chassis. No panning of any kind may extend rearward beyond the rear edge of the driver's tub.

Roll Cage

1. CARS Officials must approve roll cage designs. Round steel tubing 1 ¾" OD round tubing by .090" minimum wall thickness must be used to construct roll cage. Roll cage should be box type with a cross support in the back and a minimum 9-inch upright support at the left front support.

2. Left door must have four bars and must have 1/16-inch minimum steel plate on all door bars.

Sway Bars

1. The main body of the front sway bar must be made of steel and may be splined for attaching to the main body. Helm joints may be used for attaching the sway bar arms to the lower control arms.

Pro Late Model Rule Enforcement

1. The chief Tech Inspector shall be authorized to make changes from any specification contained in these rules as a situation may dictate. Furthermore, the Chief Tech Inspector may impose further restrictions in an attempt to maintain fairness. Under no circumstances may the Tech Inspector alter any safety rule to less than stipulated.
2. ANY VARIANCE OF THESE RULES BY PARTICIPANT THAT MAY ULTIMATELY LED TO A REDUCTION IN SAFETY, OR AN INCREASED RISK, TO ANY PARTICIPANT, SHALL BE EXCLUSIVELY RESPONSIBLE AND LIABLE OF PARTY OR PARTIES RESPONSIBLE FOR THE VARIANCE. THE MANAGEMENT OF THE CARS TOUR SHALL NOT BE RESPONSIBLE OR LIABLE FOR RULES AS PROVIDED.
3. CARS OFFICIALS RESERVE THE RIGHT TO CONFISCATE THE PARTS.

2022 ABC Approved Body Measurements

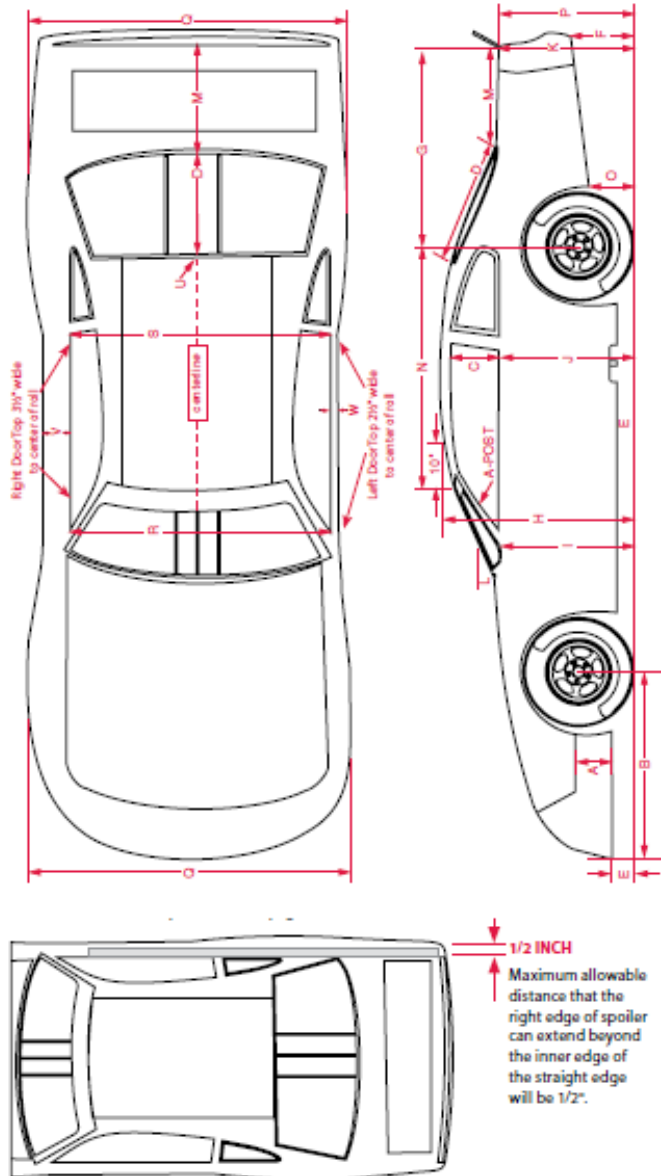

A	NOSE FLAP HEIGHT: from bottom of nose to top of side flap***	13"
B	FRONT OVERHANG (MAX): on centerline	46"
C	SIDE WINDOW OPENING (MIN): at B-post	15"
D	REAR WINDOW LENGTH: on centerline** Five Star bodies AR bodies	31½" 31¼"
E	NOSE/SIDE PANEL CLEARANCE (MIN): from ground	4"
F	BUMPER COVER HEIGHT (MAX): from ground	15"
G	REAR OVERHANG (MAX): from base of spoiler at centerline to axle centerline	47"
H	ROOF HEIGHT (MIN): 10" back from windshield, on centerline	47"
I	FENDER HEIGHT: at rear	32½"
J	DOOR HEIGHT (MIN): at rear	33"
K	QUARTER PANEL HEIGHT: at bumper cover/deck lid intersection (+/-¼")	34½"
L	WINDSHIELD ANGLE: at center/at roof windshield post	26/30°
M	REAR DECK LENGTH (MAX): at center, from base of spoiler to rear window** Five Star bodies AR bodies	23¼" 23"
N	FRONT OF ROOF TO CENTER OF REAR AXLE	57½"
O	QUARTER PANEL HEIGHT: at back of wheel well opening	13"
P	BUMPER COVER HEIGHT: at base of spoiler, on centerline	34¼"
Q	BODY WIDTH (MAX): at wheel wells	79½"
R	DOOR TO DOOR WIDTH (measured through car): at A-posts and inside edges of doors	68"
S	DOOR TO DOOR WIDTH (measured through car): at B-posts and inside edges of doors	67"
U	ROOF HEIGHT, REAR: at centerline	45½"
V	RIGHT DOOR TOP: to center of roll	3½"
W	LEFT DOOR TOP: to center of roll	2½"

* If Dimensions H, I, J, K or P are higher than the stated dimensions, all five must increase by the same amount.

** Must fit centerline template within allowable tolerance.

*** 13 inches is the height of the nose flap only. This dimension is not measured from